

PREMIUMFLEX RUBBER EXPANSION JOINT

Series 8000

Single-Sphere Rubber Expansion Joint

Applications Include:

- Air Conditioning system
- Air ducts, Chemical lines.
- Circulating water lines
- Compressor lines, paper stock lines.
- Pump-suction and discharge
- Refrigeration lines.
- Turbine to condenser.

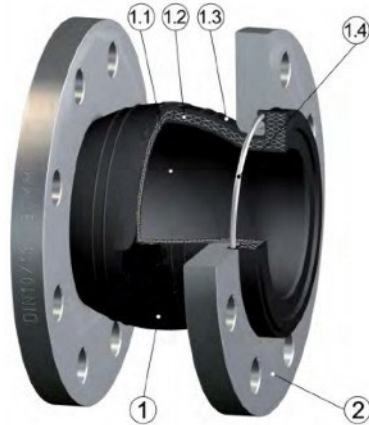

| | |
|--|--------------------------|
| 1- Vulcanized Rubber Bellows: | 1.1 Rubber core (inner) |
| | 1.2 Nylon tire cord |
| | 1.3 Rubber cover (outer) |
| | 1.4 Steel Wire |
| Rubber options: EPDM, NBR, Hypalon, Neoprene, Viton, Butyl Rubber, Natural Rubber, PTFE/EPDM | |
| 2-Loose Flanges: | |
| Flange standard: DIN,ANSI,BS,JIS,etc | |
| Flange Options: 304 316 Stainless Steel, Carbon Steel, PVC, etc. | |

| Size | | Length | Allowable Movements in Operation | | | |
|--------|-----|--------|----------------------------------|------------------------|--------------------------|--------------------|
| Inch | mm | Inch | Axial Extension Inch | Axial Compression Inch | Transverse Movement Inch | Angular Deflection |
| 1-1/4" | 32 | 6 | 3/8 | 1/2 | 1/2 | 15° |
| 1-1/2" | 40 | 6 | 3/8 | 1/2 | 1/2 | 15° |
| 2" | 50 | 6 | 3/8 | 1/2 | 1/2 | 15° |
| 2.1/2" | 65 | 6 | 3/8 | 1/2 | 1/2 | 15° |
| 3" | 80 | 6 | 3/8 | 1/2 | 1/2 | 15° |
| 4 | 100 | 6 | 1/2 | 3/4 | 1/2 | 15° |
| 5 | 125 | 6 | 1/2 | 3/4 | 1/2 | 15° |
| 6 | 150 | 6 | 1/2 | 3/4 | 1/2 | 15° |
| 8 | 200 | 6 | 1/2 | 3/4 | 1/2 | 15° |
| 10 | 250 | 8 | 5/8 | 1 | 3/4 | 15° |
| 12 | 300 | 8 | 5/8 | 1 | 3/4 | 15° |
| 14 | 350 | 8 | 5/8 | 1 | 3/4 | 15° |
| 16 | 400 | 8 | 5/8 | 1 | 3/4 | 15° |
| 18 | 450 | 8 | 5/8 | 1 | 3/4 | 15° |
| 20 | 500 | 8 | 5/8 | 1 | 3/4 | 15° |